

TOPOLOGY CONSIDERATIONS FOR RIAA
PHONO PREAMPLIFIERS

1719 (D-1)

Walter G. Jung
Forest Hill, MD

Presented at
the 67th Convention
1980 Oct. 31 / Nov. 3
New York

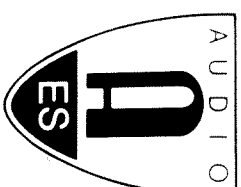

This preprint has been reproduced from the author's advance manuscript, without editing, corrections or consideration by the Review Board. The AES takes no responsibility for the contents.

Additional preprints may be obtained by sending request and remittance to the Audio Engineering Society, 60 East 42nd Street, New York, New York 10017 USA.

All rights reserved. Reproduction of this preprint, or any portion thereof, is not permitted without direct permission from the Journal of the Audio Engineering Society.

AES

AN AUDIO ENGINEERING SOCIETY PREPRINT

TOPOLOGY CONSIDERATIONS FOR RIAA PHONO PREAMPLIFIERS

Walter G. Jung
Independent Consultant
Forest Hill, MI

~~ABSTRACT~~

In addition to the basic process of amplification and frequency response normalization, RIAA phono preamplifiers must be optimized for performance with regard to noise, linearity, power, and device economy. This paper considers the basic differences between the topology tradeoffs.

INTRODUCTION

One of the most heavily discussed areas of audio circuitry is the RIAA phono playback preamp. Much engineering attention has been focused upon it, yet there is still incomplete agreement upon "which way is best". This paper examines the topological differences between two alternate approaches to the task, the use of active versus passive equalization. Neither is inherently superior from all standpoints, and each has some salient features.

FEEDBACK EQUALIZED PHONO STAGES

The popular method to accomplish RIAA equalization is to employ frequency dependent feedback around a high quality amplifier gain block. By selection of an appropriate RC network to provide the 3 time constants of 3180, 318 and 75 μ s (3) the task can be efficiently accomplished.

Figure one is an example of such a phono circuit using a unity gain stable, wideband amplifier for A1. R1-R2-C1-C2 form the RIAA network, providing an accurate realization with standard component values. These components should be precision, high quality types of course, both for initial equalization accuracy, and also for minimal errors from non-ideal properties. High quality metal film resistors and film capacitors of polyethylene or polypropylene are recommended, as they have low voltage coefficients, dissipation factors, and low dielectric absorption. A good example of a type of capacitor type to be avoided are the high K ceramic families. However, it is also worth noting that low K ceramics such as NPO types have excellent dissipation factors, and although their DA might not be as low as the best films, they may be worth consideration for small values and/or where space is a premium. Obviously the quality of equalization/amplification can be no better than the components used to determine the transfer function (even if the amplifier were perfect). These comments apply to all circuits to follow.

In terms of the desired amplifier parameters for optimum performance in this circuit, they are considerably demanding. For lowest noise from the cartridge's inductive source the amplifier should have a voltage noise density of $5nV/\sqrt{Hz}$ or less, and a current noise density of $1 pA/\sqrt{Hz}$ or less. The former is

best met by bipolar input amplifiers while the latter by FET input amplifiers (1, 2). For bipolar input amplifiers DC input bias current can be a potential problem with direct coupling to the cartridge, in which case bias current compensation can be employed, by using the current source IB (1). This will allow net input currents less than 100nA. FET input amplifiers have negligible bias currents, but tend to typically have higher voltage noise.

For high gain accuracy, particularly at high stage gains, the amplifier should have a high gain-bandwidth product; preferably 5 MHz or more at audio frequencies. Because of the 100% feedback at high frequencies through C1-C2, the amplifier must be a unity gain stable type.

To minimize noise from sources other than the amplifier, R3 is set to a value which generates a voltage noise low in relation to that of the amplifier used.

The 100 ohm value used here generates a $1.3\mu V/\sqrt{Hz}$ noise, which will increase a $5\mu V/\sqrt{Hz}$ amplifier noise by only 0.3dB.

The 1kHz gain (G) of the circuit can be calculated by the expression

$$G = 0.101 \left(1 + \frac{R1}{R3} \right)$$

For the values shown, the gain is just under 100 times (or 40dB). Lower gains can be accommodated by increasing R3, but gains higher than 40dB may show increasing equalization errors, dependent upon the gain-bandwidth of the amplifier used.

Dependent upon the amplifier, this circuit is capable of very low distortion over its entire range, generally below 0.01% at levels up to 7V rms, assuming 15V supplies. With high output devices (8,9), outputs up to 15V rms are

possible with 24 or 28V supplies.

C3 and R4 form a simple-60dB per octave rumble filter, with a corner at 22Hz. Placing a rumble filter's high pass action after the preamp has the desirable property of discriminating against the RIAA amplified LF noise components, in addition to pickup produced LF disturbances.

As can be noted from the figure's simplicity, C3 is the only DC blocking capacitor in the circuit. In as much as the DC gain of the circuit is on the order of 60dB, the amplifier used must be a low offset voltage device, with an offset voltage insensitive to the source. This implies an offset voltage on the order of 1mV, and a bias current of 50nA or less. Both of these requirements are realistic in terms of current devices. However, in light of the fact that they must be met consistent with bandwidth, power output, and slew rate, the designer may also wish to consider composite connections (1).

PASSIVELY EQUALIZED PHONO STAGES

A current area of high audiophile interest is passively equalized preamplifier circuits for disc signal sources. A circuit topology which can be used for such RIAA phono applications is shown in figure 2.

This circuit consists of two high quality gain blocks, A1 and A2, each of which is set up for the required gain via R2 and R1, and R4 and R3. Input termination as appropriate to the particular cartridge used is provided by Rt and Ct, which are optimized for flattest response into this passive network, as in figure 1.

Gain blocks A1 and A2 could be identical for simplicity, but are necessarily not so for reasons to follow. The gain values shown yield a 1kHz gain which

is the product of the A1-A2 gains (24.7 times 40.2), and that of the inter-stage network. For a RIAA equalized phono case, the 1KHZ gain is 0.101 times the DC gain, which yields the overall gain of 40dB. Other gains can be realized most simply by minor increments to R4. In general the 1KHZ gain of this circuit is

$$G = 0.101 \left(1 + \frac{R_2}{R_1} \right) \left(1 + \frac{R_4}{R_3} \right)$$

A passively equalized preamplifier such as this must be carefully optimized for signal handling capability, both from an overload standpoint and from a low noise viewpoint. Stage A1 is desirably chosen for a gain sufficiently high that input referred noise will be predominantly due to this stage (and the cartridge, when connected), but yet not so high that it will readily clip at high level, high frequency inputs. Several amplifiers with a 10V rms output capability will allow A1 to accept 400mV rms at high frequencies as shown, with 18V supplies. Even higher levels are possible, using high output devices.

The above factors dictate that the gain distribution between A1 and A2 is LOW/HIGH from an overload standpoint, but HIGH/LOW from a noise standpoint. Practically, these conflicting requirements can be mitigated by choosing the highest allowable supply voltage for A1, and the lowest noise device. Because of the near 40dB loss in the network N at 20KHZ, output overload of the circuit will be noted at high frequencies first. With the gain distribution chosen the circuit will allow a 3V rms undistorted output to 20KHZ, with 15V supplies; and proportionally more with higher supply voltages.

Further, the equalization network "N" which follows A1 should use the lowest impedance values practical from the standpoint of low noise, as the noise output at pin 2 is equivalent to the input referred noise of A2. A2's noise

is less critical than A1 at low frequencies, but still not negligible. A low noise voltage density device is very valuable to the A1 and A2 positions, as is a relatively low input current noise.

Bias current compensation may be appropriate to both A1 and A2, with bipolar amplifiers. With a 100mA or less bias current device (or compensation), direct coupling to a moving magnet phono cartridge is practical, as a 50mA bias current will induce only an 50mV offset at A1, for a typical 1K cartridge. Similarly, bias current induced offset voltage of A2 from the 10K DC resistance of N will be low relative to the amplified offset of A1. As a result, the worst case output DC offset at A2 can be held to under a volt, allowing single coupling capacitor to suffice for DC blocking purposes for the entire circuit. A high quality film unit is suggested, as in (4).

Equalization networks applicable to RIAA phono reproduction are illustrated in figure 3, and are largely self-explanatory. Both yield the three time constants of 3180, 318 and 75µs as outlined in (3), and convenient "no trim" values are listed for each. It is again strongly recommended that only the highest quality components be employed for these networks, as discussed above. The specific values suggested are not truly optimum from a low impedance and low noise standpoint, but practical realities for general usage will most likely deter using appreciably lower ones. The components should be adequately shielded of course, with the outside foils of C1 or C2 connected to common.

CONCLUSION

A review of the above reveals that each type of circuit has both merits and problems, and perhaps each can best be applied where the merits outweigh the disadvantages. They both can provide very accurate, gain stable equalization, given the appropriate device and component attention.

APPENDIX

Transconductance mode operation of op amps

An interesting option applicable to many op amp devices is to apply inner loop feedback via the device's balance pins, as in figure 4 (1). RA and RB provide local loop feedback around the internal stages (or stages), extending the applicable open loop bandwidth, while lowering open loop gain. This bandwidth extension removes the open loop -6dB per octave gain variation within the audible range, and minimizes the resulting closed loop signal phase modulation with signal as described in (6). This is an option of course, and if applied should be accomplished with some care, as the resistors connected to the balance pins can alter the device's DC offset and necessitate a compensatory trim to RB. Note that this technique trades open loop gain for bandwidth, consistent with the gain bandwidth of the specific device to which it is applied. In practice it is not equally applicable to all devices, simply because interfacing at the balance pins is neither standardized nor controlled.

Finally, it should be noted that the range of gain-bandwidth tradeoff possible is dependent upon the device's inherent transconductance. Low transconductance units with FEI input stages can even be operated just as shown in figure 4; with no overall feedback, at stage gains on the order of 10-30 times.

References

- 1) Jung, W.G.
- 2) Jung, W.G.
- 3) Lipshitz, S.F.
- 4) Jung, W.G.; Kersch, R.K.
- 5) Stout D.F.; Kaufman M.
- 6) Orala, M.
- 7) Marsh, R.N.
- 8) Jensen, D.
- 9) — — —

"IC Op Amp Cookbook, 2nd Edition", H.W. Sams and Company 1980.

"Audio IC Op Amp Applications, 2nd Edition" H.W. Sams and Company 1978.

"On RIAA Equalization Networks" JAES, Vol 27 #6, June 1979 PP. 458-481.

"Picking Capacitors" Part 1, Part 11 Audio February, March 1980.

"Handbook of Operational Amplifier Circuit Design" McGraw Hill, 1976.

"Feedback Generated Phase Non-Linearity In Audio Amplifiers" London AES Convention, March 1980, preprint # 1576

"A Passively Equalized Phono Preamp", The Audio Amateur, issue 3/80 June 1980.

"J3-990 Discrete Operational Amplifier" JAES, Vol 1 28 # 12, Jan./Feb. 1980, PP 26-34.

"HS-1000 Amplifier Module", Sontec Corp., Cockeysville, MD, 21030

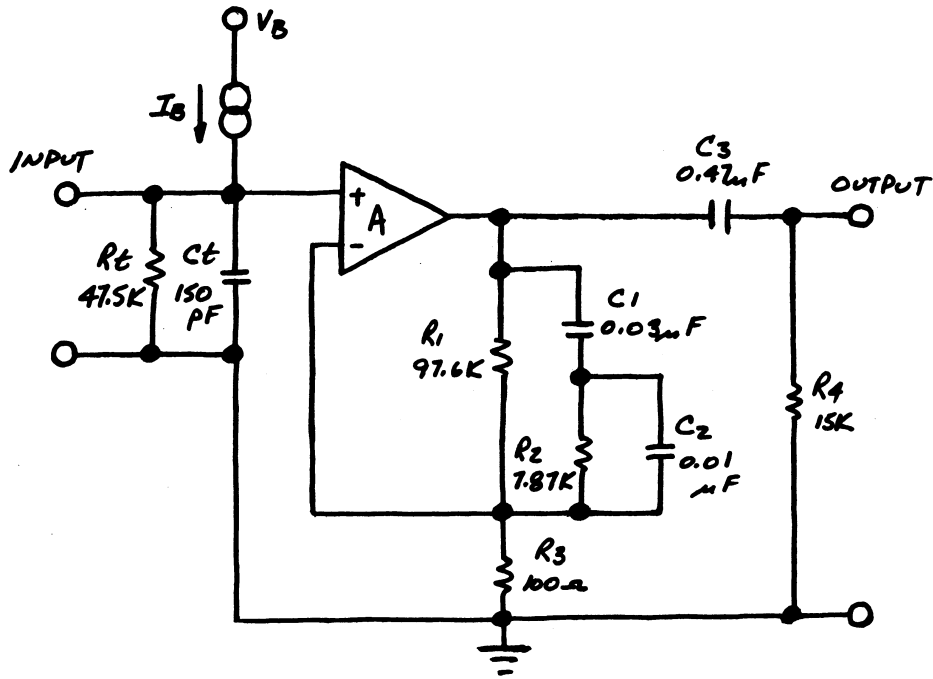

Fig. 1: FEEDBACK EQUALIZED PHONO PREAMP

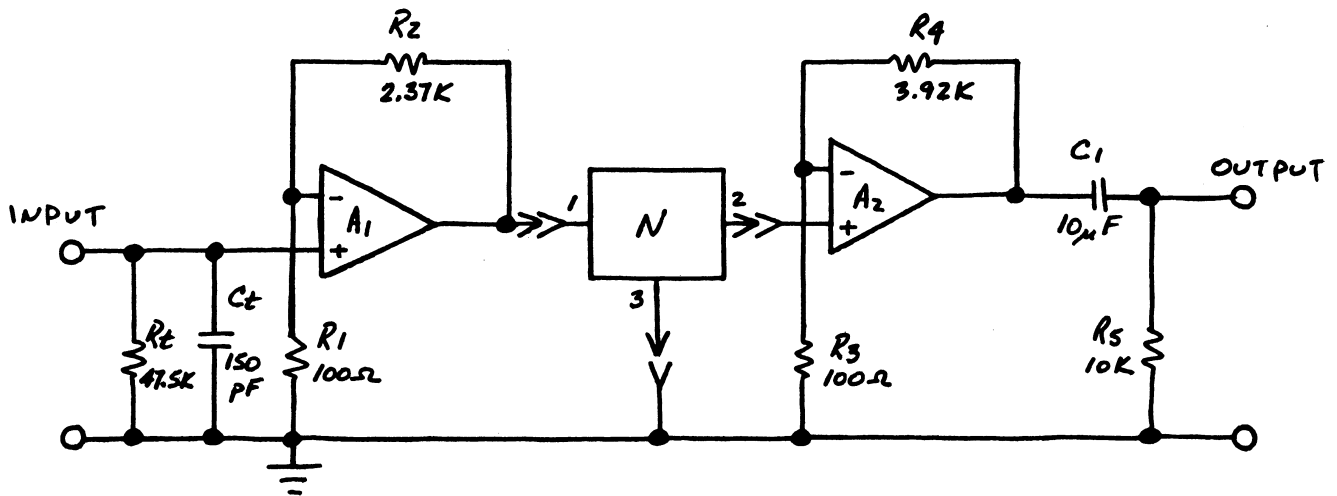
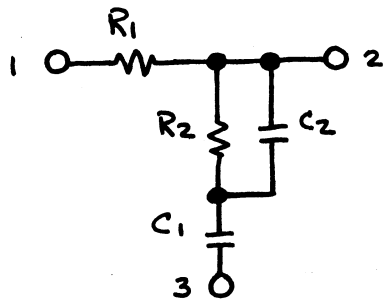
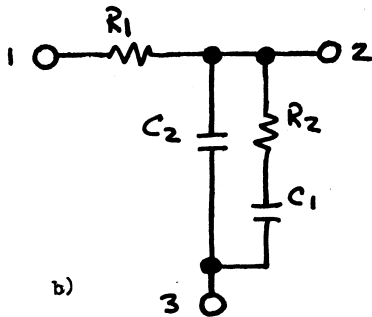

Fig. 2: PASSIVELY EQUALIZED PHONO PREAMP



a)

	Theoretical	Closest standard value
R1	9.79K	9.76K
R2	789 Ω	787 Ω
C1	0.3 μ F	0.3 μ F (base)
C2	0.103 μ F	0.1 μ F



b)

R1	7.29K	7.32K
R2	1.06K	1.05K
C1	0.3 μ F	0.3 μ F (base)
C2	0.103 μ F	0.1 μ F

Fig. 3: RIAA NETWORKS ($T_1=3180\mu s$, $T_2=318\mu s$, $T_3=75\mu s$)

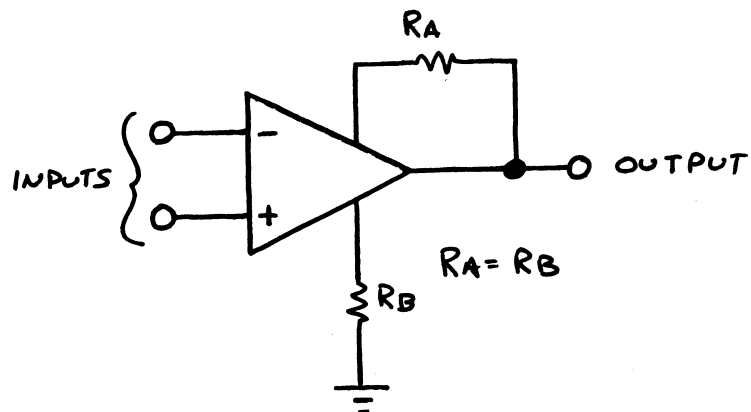

Fig. 4: TRANSCONDUCTANCE-MODE OPERATION OF OPAMP DEVICE